

26

Live Steam Boiler and Engine

It is fun to complete an engine and see it run on compressed air, but it is more fun to run it on steam. The engine and boiler described here are good starters on your Live Steam projects. They are within the capacity of a model lathe and made of quite common materials.

The **BOILER** and **BURNER** are of copper and brass construction for easy soldering. The model shown was soldered with 430° solder. After firing up a half-dozen or so times, there is no sign of failure. The 1-1/2" tubing is common sink drain pipe. The **FLUE** is 1/2" O.D. copper. The two **FILL TUBES** are 5/16" I.D. x 11/32" O.D. brass sold as telescoping tubing. An assortment package of corks from the corner hardware store had four corks that fit the 5/16" tubing.

The **LAGGING** here is sheet asbestos. It is really needed. The brass carries away the heat so fast the burner can barely keep up. Optional Lagging could be 1/28" wood veneer stock of your choice. Run the grain vertical and moisten the outside so it will bend easily and wrap around the Boiler.

While making the parts for the Boiler and Burner, try for a push fit at all solder points. The assembly will hold its shape better while soldering. The cone-shaped **TOP** makes a dead air space for insulation and makes the Boiler appear slightly more authentic. Use an escutcheon pin for a rivet in this cone. Try for a loose free fit on the Boiler. It is not soldered to the Boiler.

About 12" of fine wire was folded in the center and started in the Wick end of the Burner. With a bit of patience, it can be worked through until it shows under the fill tube. Hook it up out of the fill tube and thread the candle wicking through the wire loop. Draw it back through the tube until 3/8" of Wick is showing above the Burner. The size of this Wick bouquet determines the size of the flame.

The **ENGINE** is fairly simple and not too much will be said about the construction. The rubbing face of the

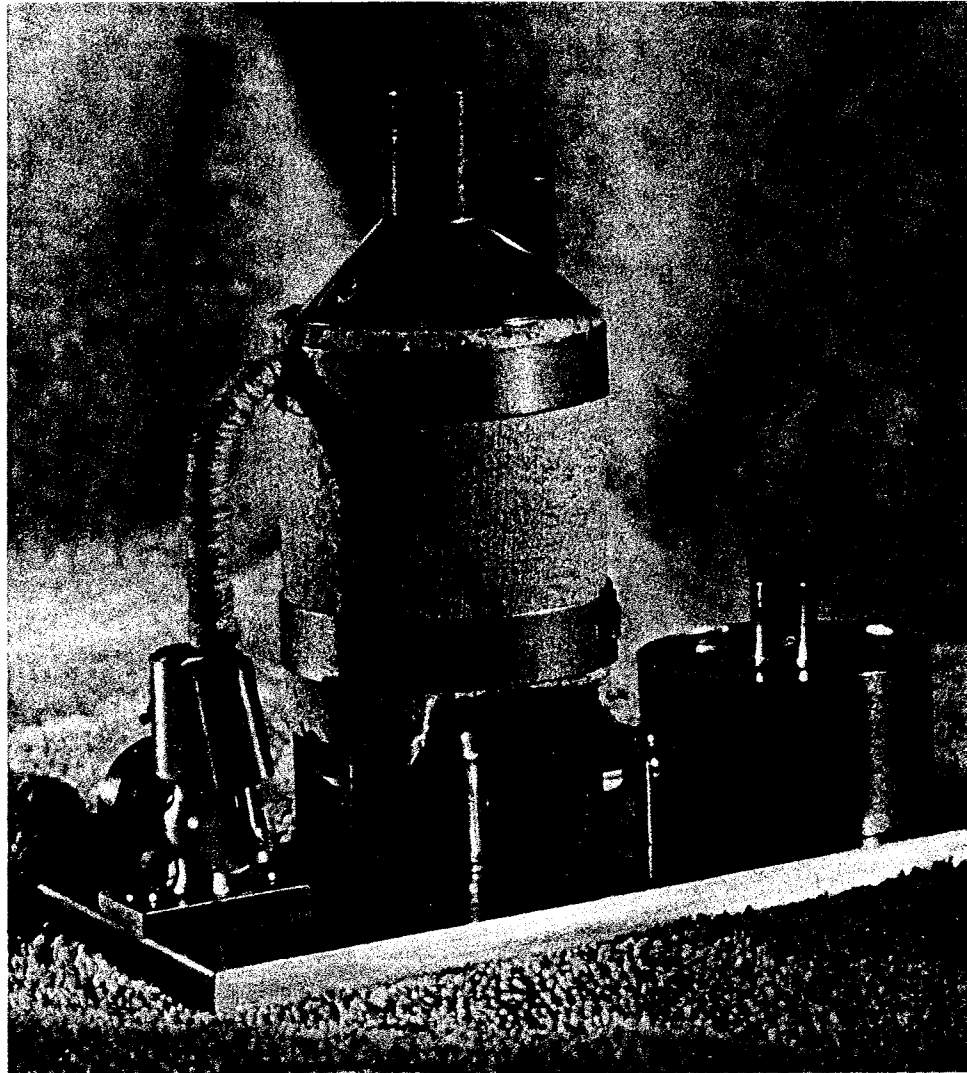

CYLINDER must be flat and smooth. Make the 1/16" Shaft a close fit so it will be square with the face when soldered. Chamfer the Cylinder slightly for the solder. Apply flux and a very tiny chip of solder and heat the Cylinder with a propane torch. By inserting a close-fitting aluminum rod in the bore, the Shaft and solder will not enter the bore or stick to the aluminum.

Try various **SPRINGS** from your collection. The one used here had the dimensions shown.

Do not run the **STEAM PIPE** in so far that it shuts off the steam passage. Thread the end #5-40 while the metal is rigid or "half hard". Mount the threaded end in a small vise and

place a piece of larger tubing over the projecting end. Play the propane torch flame on one side of the tube and slowly apply pressure, bending away from the torch. You can feel the moment the heat has removed the work-hardened condition of the tube. Take it easy and bend at a right angle. If the heat is spread evenly on the stretch side of the bend, it will hardly collapse the tube at all. At final assembly, the bent end must aim at the Boiler when it runs tight in the thread. Apply pipe joint compound to the thread. Assemble the Engine and Boiler on the Base and solder the pipe into the Boiler.

The ports in the column are made with a jig as shown. Use the shoul-

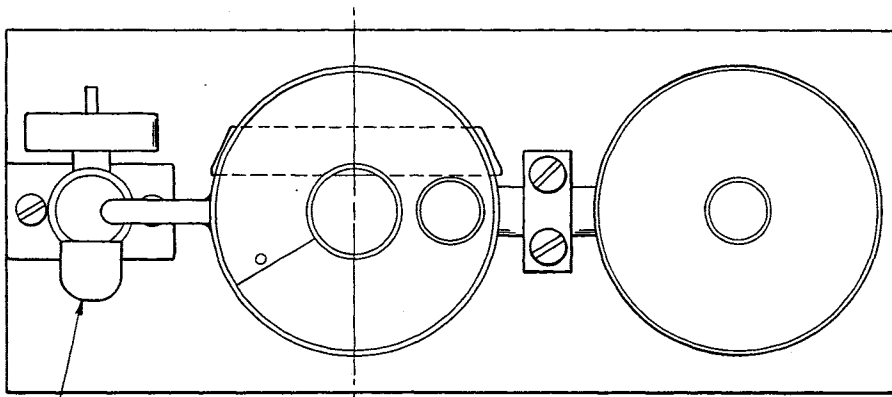

$\frac{3}{16} \times \frac{3}{16}$ engine

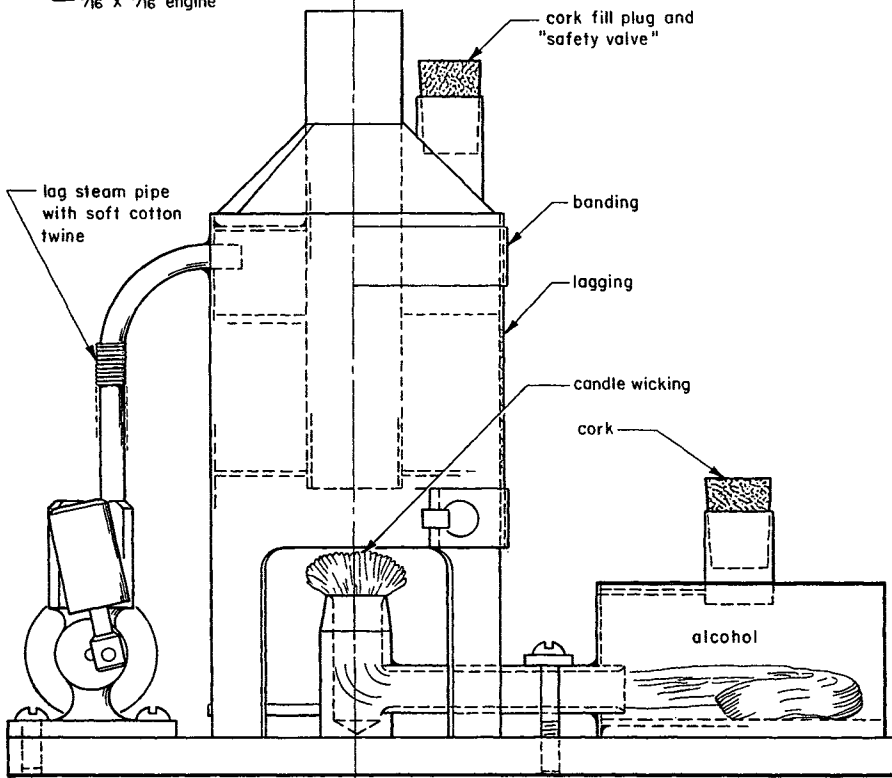

cork fill plug and "safety valve"

lag steam pipe with soft cotton twine

banding

lagging

candle wicking

cork

alcohol

dered locating pin and a $\frac{1}{16}$ " straight pin in the column. Hold the jig against the locating pin while drilling. Turn the jig over the second hole.

Use the same jig to drill the port in the Cylinder. Insert the Piston in the Cylinder. Place jig over the shaft and a $\frac{1}{16}$ " pin through the jig and Connecting Rod.

Do not seal this Boiler any tighter than provided by the cork. It will hold the 5 to 10 pounds of pressure needed and easily blow out if higher pressure develops. Do not have your face above the Boiler when operating. **Remember, you are dealing with flammable liquid, fire, hot water and steam. If you made this for your grandson, supervise his operation of this model.**

A hypodermic syringe is great for measuring the water and alcohol. The Boiler should be only about $\frac{2}{3}$ full of water. If the Boiler runs out of water (the engine stops) blow out the flame immediately

This is a good educational project with lots of operational action.

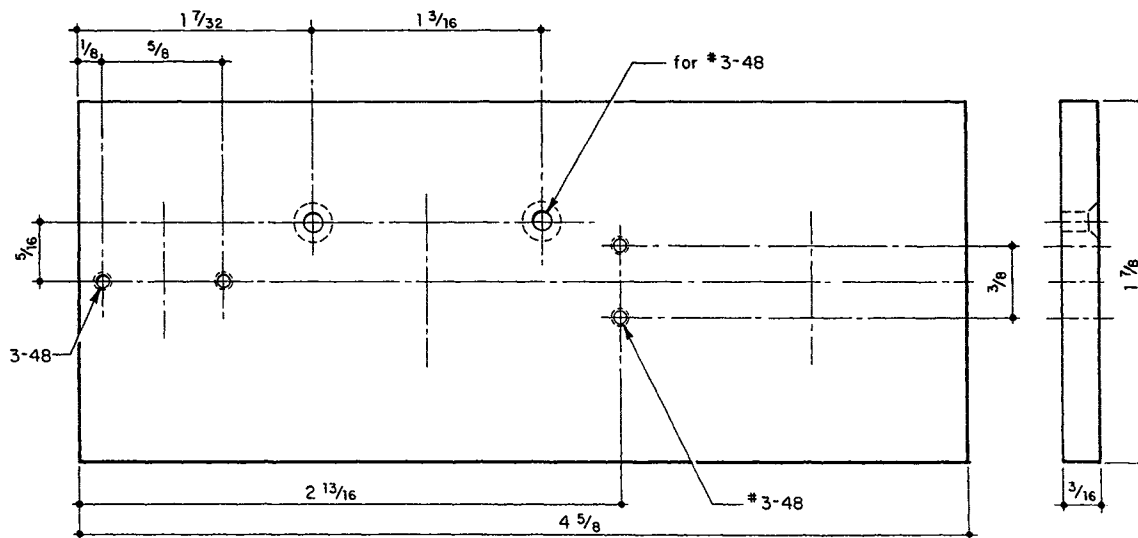

BASE

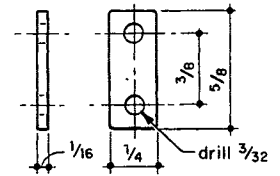
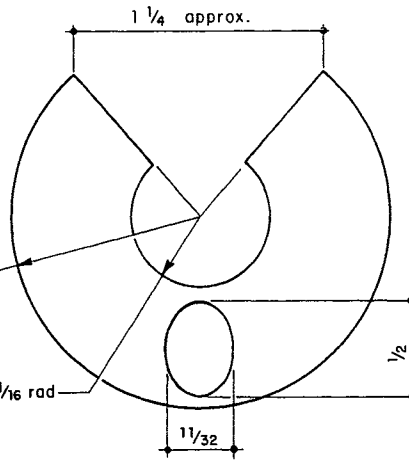
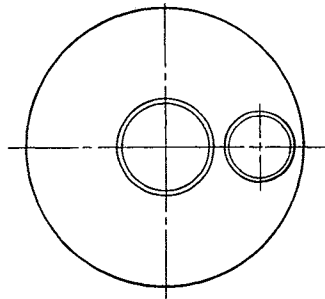

BURNER ANCHOR

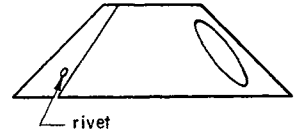

brite tin plate steel, brass, copper, or aluminum

TOP

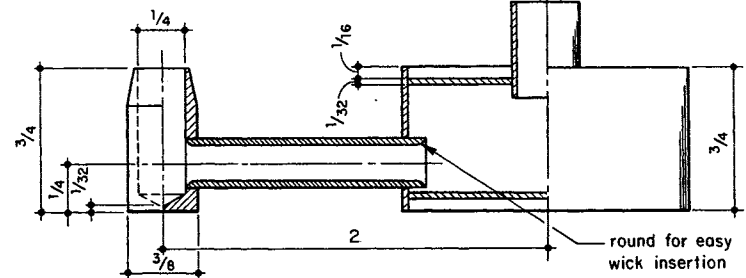
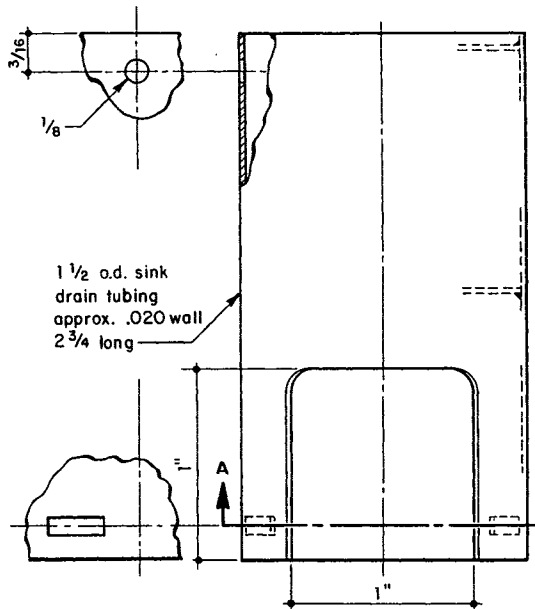
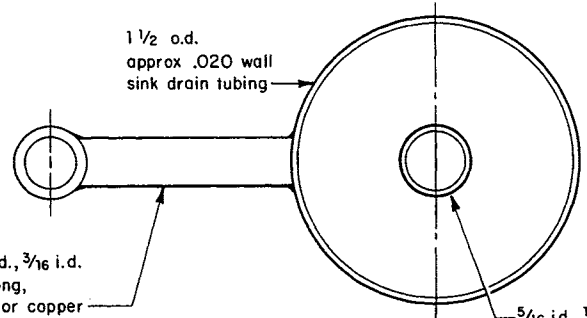
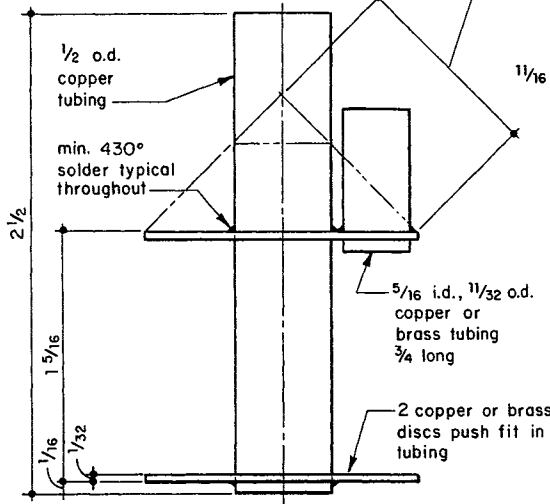

round for easy wick insertion

BURNER

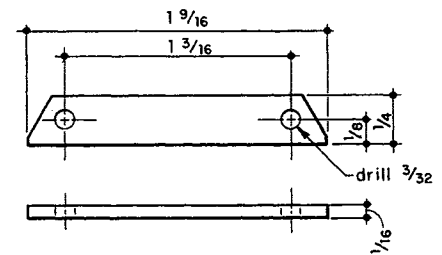

BOILER ANCHOR

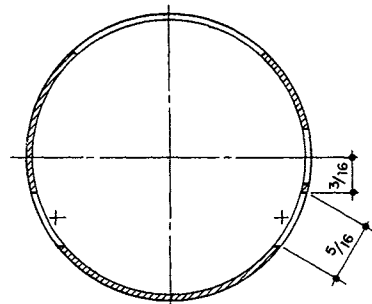

Section A-A

BOILER

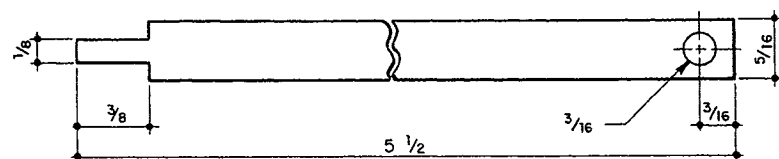

BANDING
Aluminum, Brass or Copper

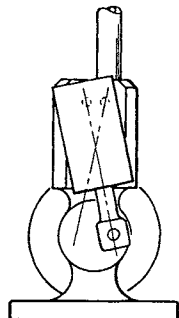
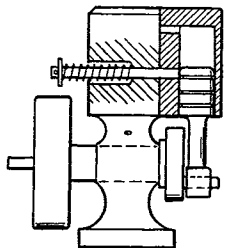
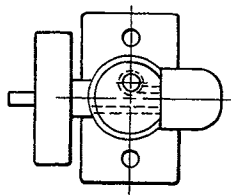

$\frac{3}{16} \times \frac{3}{16}$ WOBLER ENGINE

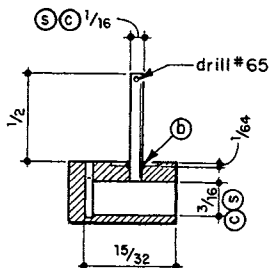
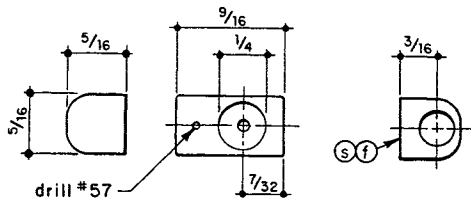

CYLINDER
Brass

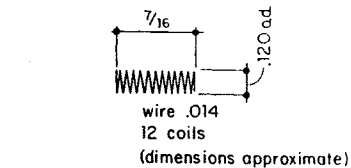
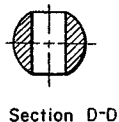
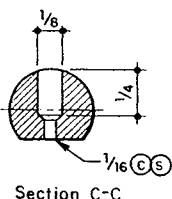
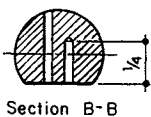

SPRING
Bronze or
Stainless Steel

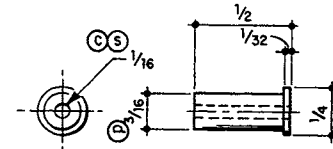

BEARING
Brass or Bronze

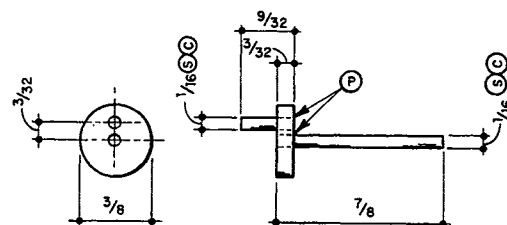

CRANKSHAFT
Brass

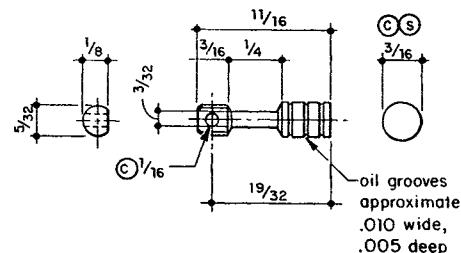

PISTON AND ROD
Aluminum

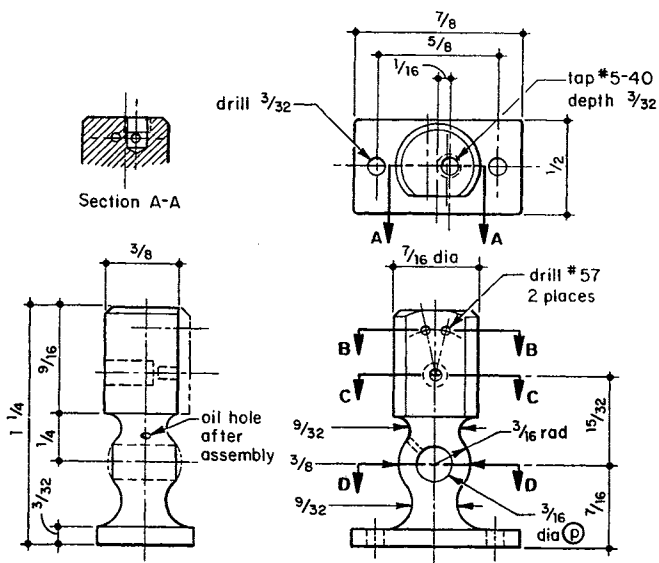

COLUMN
Aluminum or Brass

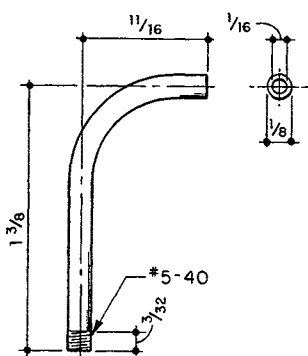

STEAM PIPE
Copper or Brass
(Half Hard)

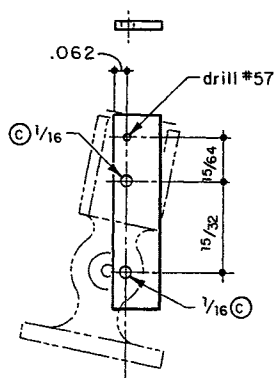

DRILL JIG

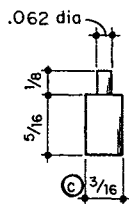

LOCATING PIN

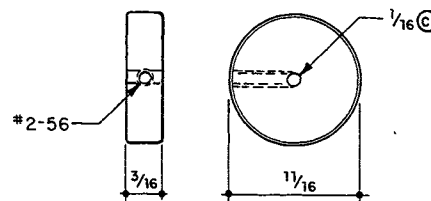

FLYWHEEL
Brass

(C) close fit	(P) press fit or loctite
(S) smooth	(b) braze or solder
(f) flat	